

DATA SHEET
Reference:
DS-PP-0323

Planterline

Technical datasheet

Planterline

Technical datasheet



Planterline

RAAFT[®] [FIND OUT MORE OR REQUEST A SAMPLE](#)
e: technical@raaft.co
w: raaft.co

Planterline

Technical datasheet

PLANTERLINE

PRODUCT NAME	COLOUR	DIMENSIONS		OTHER		
Planterline Straight	Powder Coated	Maximum straight panel length	2400mm	Material specification	Corten A, Mild Steel, Green Steel	
		Maximum returns at corners	1000mm (for ease of transport)			
Planterline Curved		Corten	Height Range	300-1100mm	Corner types	Folded
Planterline Prism			Steel thickness	3mm	Top return	40mm single top

LOADING ANALYSIS

Structural calculations for our Planterline planters have been completed to ensure they are fit for standard use. Based on the calculations made, a deflection amount was measured on four planter heights as per the below table.

PLANTER HEIGHT	PANEL DEFLECTION	WET SOIL LOAD PER M ²
300mm	0.02mm	300H - 510kg 400H - 680kg
600mm	0.14mm	500H - 850kg 600H - 1020kg 700H - 1190kg
900mm	0.66mm	800H - 1360kg 900H - 1530kg
1100mm	1.1mm	1000H - 1700kg 1100H - 1870kg

Please note this information should be used as a guide only. Please contact us if you would like further information on the structural calculations made.

 **RAAFT®** FIND OUT MORE OR REQUEST A SAMPLE
e: technical@raaft.co
w: raaft.co

Planterline

Technical datasheet

STRUCTA FLOOR PANEL APPLICATION

Suitable for roof terraces, parks, playgrounds and many other external spaces. Planterline has a high resistance to corrosive conditions in normal environments.

MEASUREMENT RANGE

100mm increments:

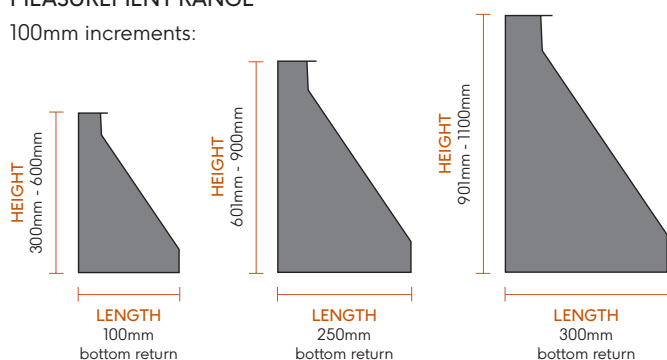

HEIGHT	WIDTH OF FIN	WIDTH OF BASEPLATE	WIRE TIE
300mm	100mm	100mm	No
400mm	100mm	100mm	No
500mm	100mm	100mm	No
600mm	100mm	100mm	No
601mm	100mm	100mm	Required
700mm	250mm	Match fin size	Required
800mm	250mm	Match fin size	Required
900mm	250mm	Match fin size	Required
901mm	300mm	300mm	Required
1000mm	300mm	Match fin size	Required
1100mm	300mm	Match fin size	Required

RAAFT® FIND OUT MORE OR REQUEST A SAMPLE
e: technical@raaft.co
w: raaft.co

Planterline

Technical datasheet

CONCRETE FIXING APPLICATION

Suitable for roof terraces, parks, playgrounds and many other external spaces. Planterline has a high resistance to corrosive conditions in normal environments.

HEIGHT	WIDTH OF FIN	WIDTH OF BASEPLATE	MESH
300mm	100mm	100mm	No
400mm	100mm	100mm	No
500mm	100mm	100mm	No
600mm	100mm	100mm	No
601mm*	100mm	100mm	Yes
700mm*	250mm	Match fin size	Yes
800mm*	250mm	Match fin size	Yes
900mm*	250mm	Match fin size	Yes
901mm*	300mm	Match fin size	Yes
1000mm*	300mm	Match fin size	Yes
1100mm*	300mm	Match fin size	Yes

* From 601 - 1100mm use A193 Mesh min. C25/30 concrete

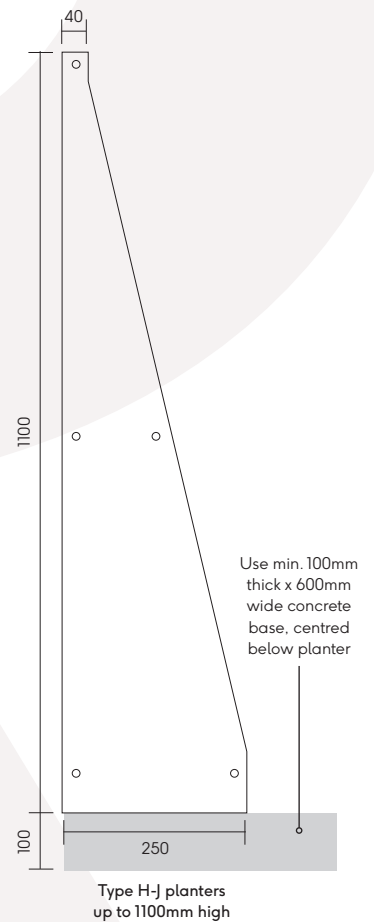
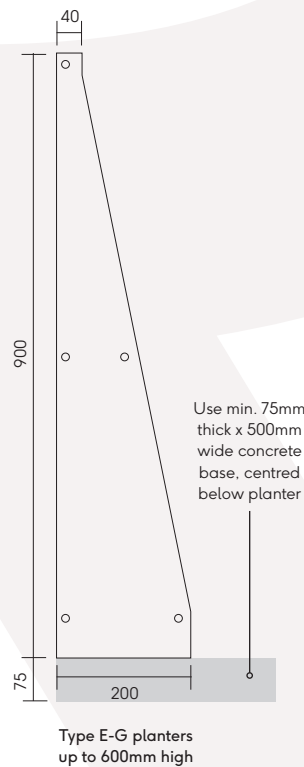
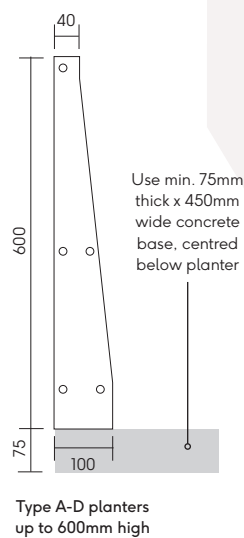

RAAFT® FIND OUT MORE OR REQUEST A SAMPLE
e: technical@raaft.co
w: raaft.co

Planterline

Technical datasheet

STRENGTHENING OPTIONS

All planters higher than 600mm.

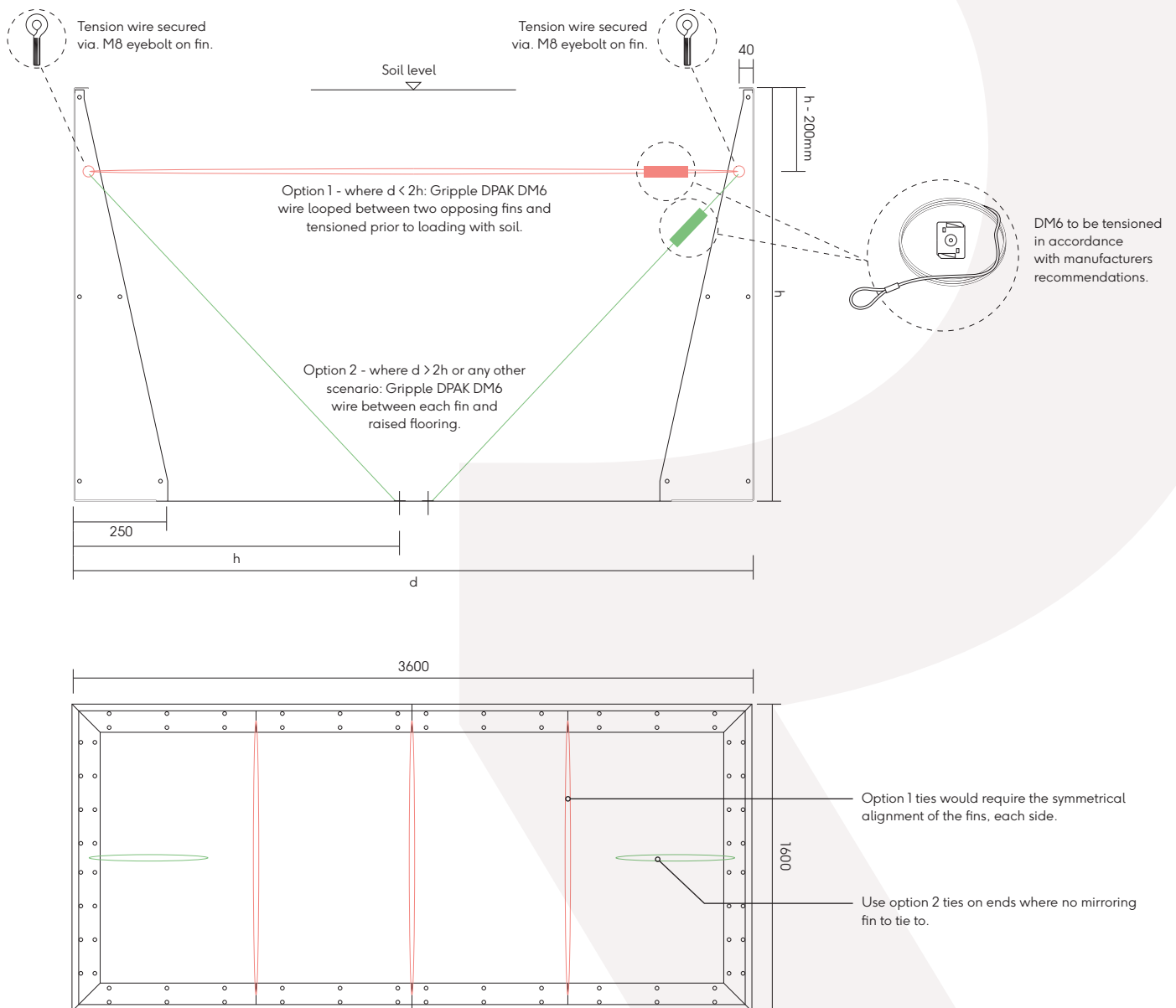

RAAFT® FIND OUT MORE OR REQUEST A SAMPLE
e: technical@raaft.co
w: raaft.co

Planterline

Technical datasheet

ACCESSORIES



Lockable cabinet

Used within the planter walls (welded in place) for access or storage of weatherproof products/items. It can accommodate IP67 rated power sockets and lighting boxes for external lighting. For added security, a panel lock, complete with a key, prevents unauthorized access.

The cabinet comes in the following sizes:

500(H) x 600 x 200 mm

400(H) x 500 x 200 mm

250(H) x 300 x 200 mm

Lighting detail

Illuminate your planters with our lighting options. Feel free to contact any member of our team if you're keen on enhancing your planters with a touch of light.

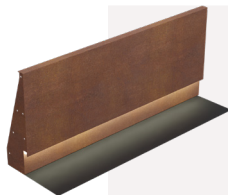

INSTALLATION INFORMATION

The installation is then completed by covering the extent of the floor structure panels, which pass beyond the planter perimeter with porcelain tiles. To secure the planter into concrete, we advise from past planter installations, the creation of a 300mm wide by 150mm deep concrete race around the planter's perimeter. M10 through bolts (supplied by Raافت®) are used for fixing down the planter into the concrete. Bracing becomes necessary for planters

exceeding a height of 600mm. This is to account for potential loads imposed by soil and any additional stresses within a terrace environment. The recommended bracing solutions for Raافت® planters include tensioning wire or a metal strap spanning from one side to the other.

PRODUCT FINISHES

Corten A is a type of weathering steel which was developed to remove the need for regular painting and rust-prevention maintenance.

This is achieved by the formation of a natural stable coating of dark brown oxidation across the metal's surface which acts as a barrier to the corrosive effects of rain, snow and other weather conditions. When delivered the Corten will contain mill-scale which will remove over time prior to the natural stable coating of dark brown being achieved. The weathering process can take around 18 months.

Powder coating starts with shot-blasting of the steel which removes mill-scale, oxide dirt, oil and grease from the substrate; followed by

a 7-stage zinc phosphate pre-treatment process for to prepare the surface. The product then receives the polyester powder coating to the requested colour. Polyester has excellent exterior durability and colour retention. Numerous colour options from world leading powder manufacturers are available.

Choose from these finishes:



Corten



PPC

 **RAAFT®** [FIND OUT MORE OR REQUEST A SAMPLE](#)
e: technical@raaft.co
w: raaft.co

Planterline

Technical datasheet

SUSTAINABILITY

Planterline is crafted from two material options: Untreated steel or Stainless Steel, and it boasts 100% recyclability. Consequently, Planterline stands out for its outstanding whole-life cost, as it is marketed with recycling in mind rather than incurring disposal costs. The primary component in steel production is iron, ranking second only to aluminium in terms of its natural abundance in the Earth's crust. Considering current extraction rates, there exists a sufficient iron supply to sustain production for well over 1000 years.

STEEL

Mild steel is widely recognized as a sustainable material for several compelling reasons:

1. Longevity and Durability

Mild steel boasts exceptional longevity and durability. When compared to less robust materials, it provides extended service over many years. For instance, while other materials may require annual replacement, using mild steel every five years significantly reduces the environmental impact, as it necessitates less energy for continuous replacement.

2. Versatility

Mild steel offers high versatility in terms of shapes and sizes during production. Its malleability allows it to take on various forms, making it highly adaptable and suitable for a wide range of applications.

3. Recyclability

One of the most significant sustainable advantages of mild steel is its recyclability. While the percentage of recyclable content may vary by type, it typically contains a high percentage of recyclable material. This aligns seamlessly with its versatility, as any surplus steel from manufacturing processes can be repurposed for smaller products or recycled, making it an environmentally friendly metal choice.

4. Absence of Harmful Chemicals

Unlike some other metals, the production of mild steel does not involve the release of harmful chemicals or toxins. This characteristic contributes to its eco-friendliness.

PRODUCT MAINTENANCE

STEEL

For the Planterline, the steel is powder coated. This will require little/no maintenance as there won't be any interaction between this part of the product and the user.

FIRE PROTECTION

Planterline planters are made using Corten A, or Mild Steel, neither of which burn nor pose a fire hazard.

Corten A is high performance materials that display excellent resistance to atmospheric corrosion when compared to other steels, making them exceptionally suitable for bespoke planter applications.

PROTECTIVE EQUIPMENT

We recommend that PPE (Personal Protective Equipment) is used when installing the Planterline:

- a) Good strong safety boots/shoes to protect the feet.
- b) Protective eyewear such as safety glasses.
- c) Strong gloves to protect the hands.
- d) If using loud cutting equipment then ear plugs or defenders should be worn.

Planterline

Technical datasheet

STORAGE AND HANDLING

The product is securely packed and sealed in clear plastic sleeving to ensure no movement of the product in transit. Depending on the size/weight of the consignment this may be palletised.

Whilst there is no specific weight restrictions on what is or is not safe to lift in manual handling, an assessment of the health and safety risks should be undertaken and measures taken to reduce the risk of injury so far as reasonably practicable.

The following guidelines may be useful:

- a) Each person should be fully trained in manual handling techniques.
- b) The use of handling aids such as a trolley, folk-lift, pallet truck or conveyor should be used if moving large volumes of cartons.
- c) Break up large consignments into more manageable loads.
- d) Ensure that the product is stored at a reasonable height, so avoiding the lifting of cartons from floor level or above shoulder height.

PLANTERLINE BOXES

Material

Mild Steel powder coated, Corten & green steel

Installation

1. The planters are installed similar to our standard planter systems. These products are standard size planters that are efficient in steel cutting and manufacture. No bolting together. Fully welded square boxes
2. Standard self-drilling screws for baseplate
3. To be fixed upon floor structure panel system
4. Can be fitted in any location. Floor structure panels to be as per the position of the planters.

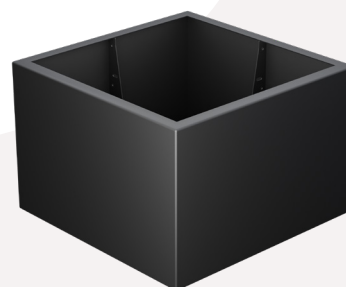

700 x 700 x 470H planter

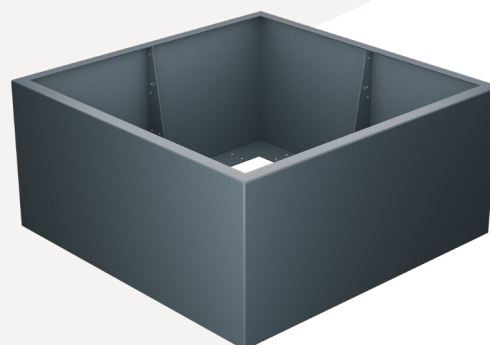

1000 x 1000 x 470H planter

 **RAAFT®** FIND OUT MORE OR REQUEST A SAMPLE
e: technical@raaft.co
w: raaft.co